

陶瓷谐振器 Ceramic Resonators Unit
 产品型号 HERC31-ZTA & ZTT SMD

产品特征 Features

- 低阻抗 Low Resonant Impedance
- 低成本 Low Cost

外形尺寸(单位:毫米)

Figure and Dimensions(Unit: mm)

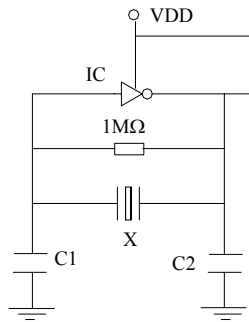
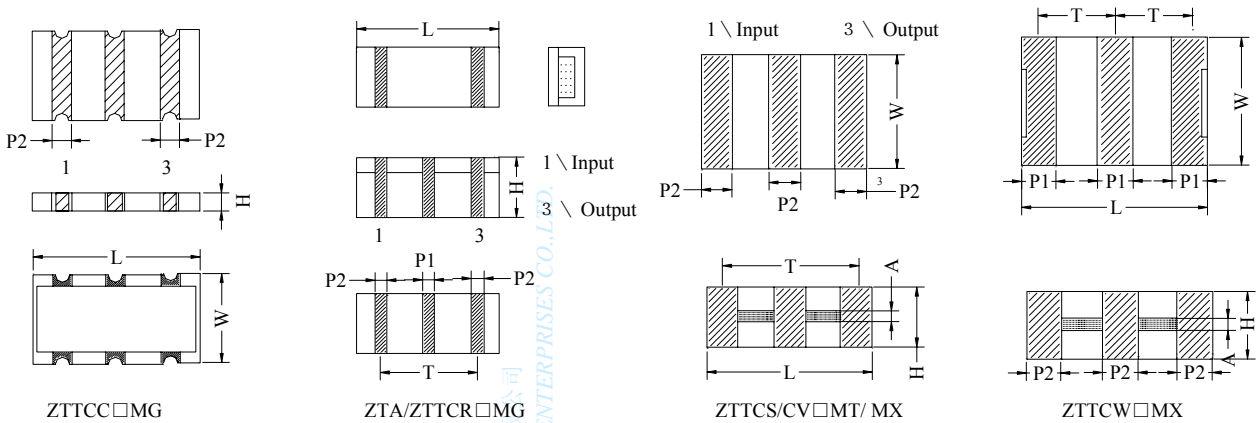

ZTA SMD

测试电路 Test Circuit

IC(MG,MT) : 1/6TC4069UBP X2
 (MX) : 1/6TC74HCU04 X2
 C1C2(MG,MT) : 30pf
 (MX) : 30pf(F<20.0MHz)
 15pf(20.01~25.99MHz)
 5pf(26.00~50.00MHz)
 X : Ceramic Resonator
 VDD(MG,MX) : +5V
 (MT) : +12V

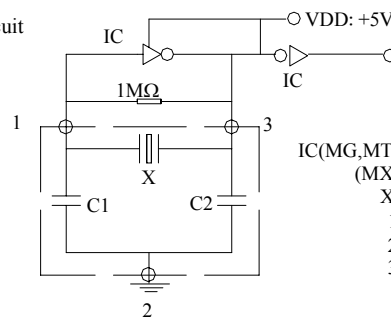

ZTT SMD

器件号 Part Number	尺寸表 Dimensions Table (Unit: mm)					
	L	W	H	P1	P2	T1
ZTACC□MG ZTTC□MG	7.4±0.2	3.4±0.2	1.8±0.2	1.2±0.2	1.2±0.2	5.0±0.2 2.5±0.2
ZTACR□MG ZTTCR□MG	4.5±0.2	2.0±0.2	1.2 max	0.8±0.2	0.8±0.2	3.0±0.2 1.5±0.2
ZTACS□MT/MX ZTTCS□MT/MX	4.7±0.2	4.1±0.2	(1.2+A)±0.2	1.0±0.2	0.8±0.2	3.9±0.2 1.95±0.2
ZTACV□MT/MX ZTTCV□MT/MX	3.7±0.2	3.1±0.2	(1.0+A)±0.2	0.9±0.2	0.7±0.2	3.0±0.2 1.5±0.2
ZTACW□MX ZTTCW□MX	2.5±0.2	2.0±0.2	1.5 max	0.5±0.2	0.4±0.2	2.0±0.2 1.0±0.2

注意事项：其中 A 为振子厚度随频率变化，范围在 0.1~0.7 毫米，ZTA 系列产品无（中间）接地电极。
Note: A stands for thickness of the ceramic element, which the frequency. The range of the thickness is 0.1 to 0.7mm
No middle terminal for ZTA series.

产品规格 Specification

器件号	频率范围	频率精度	温度稳定性	老化率
Part Number	Freq.Range (MHz)	Freq.Accuracy	Stability In Temp (-20℃ ~ 80℃)	Ageing for Ten Years
ZTACC□MG	1.79~8.00	±0.5%	±0.3%	±0.3%
ZTTCC□MG				
ZTACR□MG	4.00~8.00	±0.5%	±0.3%	±0.3%
ZTTCR□MG				
ZTA/ZTTCS□MT	6.00~13.00 / 8.00~13.00	±0.5%	±0.4%	±0.3%
ZTA/ZTTCV□MT				
ZTACS□MX	13.01~60.00	±0.5%	±0.3%	±0.3%
ZTTCS□MX				
ZTACV□MX	16.00~60.00	±0.5%	±0.3%	±0.3%
ZTTCV□MX				
ZTACW□MX	20.00 ~60.00	±0.5%	±0.3%	±0.3%
ZTTCW□MX				

订购须知 Order Information
HERC31□-Frequency-Packaging

HERC31□	产品系列 Product Family ZTA & ZTT SMD
	<ul style="list-style-type: none"> ■ A for ZTA ■ B for ZTT
Frequency	频率 Frequency(MHz)
Packaging	包装 Packaging
	<ul style="list-style-type: none"> ■ T for Tape & Reel ■ B for Bulk

订购举例：Example : **HERC31A-2.500MHz-B**

HERC31A	产品系列 Product Family ZTA & ZTT
	<ul style="list-style-type: none"> ■ A for ZTA
2.500MHz	频率 Frequency \ f ₀ =2.500MHz
B	包装 Packaging for Bulk

[Http:// www.horizonxtal.com](http://www.horizonxtal.com)

国际贸易 Horizon International Marketing

国内贸易 Horizon Domestic Marketing

E-mail: horizoncrystals@163.com

E-mail:hqq226@163.com

Fax: 0086 731 8442 2043

Fax: 0086 731 8805 0850

Tel: 0086 731 8442 3897 / 8222 4572

Tel: 0086 731 8805 0851 / 8805 0780